

GOEBEL
innovative fastener solutions

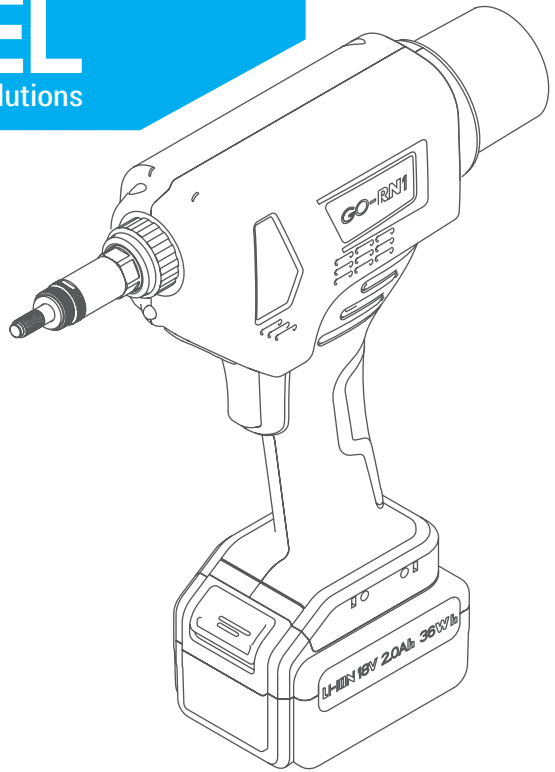

GO - RN1

GO - RN2

GO - SN1

⚡ 18V

Cordless Blind Rivet Nut Battery Tool



Instruction manual: GO-RN1 / GO-RN2 / GO-SN1**Table of contents**

	Page
Safety precautions	2 - 4
Daily maintenance & environmental protection	4
1. Tools overview	4
1.1 Capacity	5
1.1 Technical parameters	5
1.2 Configuration/ Accessories (see fig. A)	5 - 6
1.3 Part list (see Fig. B)	7
1.4 GO-RN series tool parts list	8
2. Preparation of the tool	9
2.1 Exchange of the mandrels	9
2.2 Setting the mandrel	9
2.3 Checking the battery	10
2.4 Checking the tool	11
3. Function setting	11
3.1 Adjusting the traction force	11
3.2 Adjusting the stroke	12 - 13
3.3 Setting the riveting mode	14
3.4 Riveting in fully automatic riveting mode	14
3.5 Riveting in conventional riveting mode	14
4. Tool Operation (important tips before starting work)	15
4.1 Instructions for presetting the blind rivet nut	15
4.2 Checking the set blind rivet nut	16
4.3 Unscrewing blind rivet nuts manually	16
4.4 Setting instructions for the riveting process	17
4.5 Riveting in special applications	17
5. Charger & Batteries	18
5.1 Technical parameters	18
5.2 Use of the charger	18
5.3 Use of the battery	18
6. FAQ (Questions / Answers)	19
7. Troubleshooting	19
7.1 Malfunctions	19
7.2 Possible causes	19
7.3 Corrective measures	19
8. Protection conditions & CE certification	20



Safety precautions

To reduce the risk of electric shock, personal injury, fire and property damage, be sure to follow the safety precautions below.

Description of the symbols:

 Danger Indicates potential danger of serious injury or death
 Warning Indicates potential danger of serious injury or death
 Caution Indicates the risk of minor injury or loss of property

The following symbols are used to classify and describe the types of description to be followed.

 This sign is used to alert the user to the prohibited action steps.
 This sign is used to draw users' attention to the operating steps that must be carried out to use the appliance

- This tool is restricted to riveting blind rivet nuts and must not be used for impact or other purposes, such as a hammer.
- Do not overload the blind rivet nut tool. Please use it only within the range specified in the function settings (see page 10-12).
- Do not block the ventilation openings of the motor. Do not insert any objects into the ventilation openings.
- It is recommended to wear safety glasses and personal protective equipment such as gloves, hard hat, safety shoes, noise-insulating earplugs and fall protection devices and other necessary protective measures when using this tool.
- Please keep the packaging boxes and accessories in a safe place and handle them with care.
- The tool and accessories should be placed in the plastic case, kept in a dry place and out of the reach of children.

-  Please keep the packaging boxes and accessories and handle them with care.
- The tool and accessories should be placed in the plastic case, stored in a dry place and out of the reach of children.

Safety precautions

Use of the battery

- Do not charge damaged, contaminated or wet batteries.
- Batteries must not be thrown into water or fire at any time, and used batteries must not be disposed of at will.
- Do not charge when the ambient temperature is below 0°C or above 45°C.

Use of the charger

- The original battery and the manufacturer's charger must be used for charging.
- The battery must not be charged with a damaged, dirty or damp charger.
- Do not place metal objects in the charging area as a short circuit may occur.
- This charger must not be used by persons with disabilities, mental disabilities or persons without training or knowledge unless a safety officer is on site to supervise or instruct them in the use of the charge.

Danger

- Do not use the riveting tool in a damp environment or near flammable liquids and gases. Risk of explosion!
- Do not point the riveting tool at yourself, others or animals.
- Do not load in a damp environment, near an open fire or in an environment with flammable, highly combustible gases that can easily be detonated.

Warning

- Tools should be placed so that they do not fall down to avoid unnecessary damage and safety accidents.
- When installing the battery, make sure to fix its position. After hearing a "click" sound, indicate that the battery is in place.
- When servicing this riveting tool, the battery must be removed.
- Before charging, check that the charger and its power supply equipment are in good condition.
- Use a power supply unit that matches the charger.
- Plugs, power cords and chargers should be checked regularly. If a problem is found, it should be repaired by maintenance personnel.
- Maintenance personnel must have professional skills; only qualified professionals can carry out repairs. If in doubt, please return the unit to the authorised dealer or manufacturer for repair.
- Original spare parts must be used during maintenance.

Maintenance

- Regular maintenance prolongs the life of tools with a lithium battery and should be carried out by an authorised dealer or manufacturer. In case of more frequent use, it is recommended to carry out maintenance in advance.
- Maintenance of the riveting tool is limited only to replacement of worn parts and quick wear parts, jaws, jaw sliders, etc., if necessary (see P8 for replacement accessories).
- To keep the tools in good working condition, please check the wear parts of the tools frequently. In case of wear or damage, please contact the dealer for purchase.

Repair

- The warranty period is 1 year from the date of sale. Excluded from this are quick wear parts e.g. clamping jaws, clamping jaw sliders etc.
- Failure to comply with the relevant installation and commissioning instructions or failure to follow the operating procedures may result in the warranty being invalidated.

Environmental protection and resource recovery

- When replacing lithium batteries used in this product, be sure to observe the following points:
- If your country or region has regulations, please be sure to take the old battery to a professional company for disposal.
- Do not throw old batteries into the rubbish, fire or water!

1. Tool overview

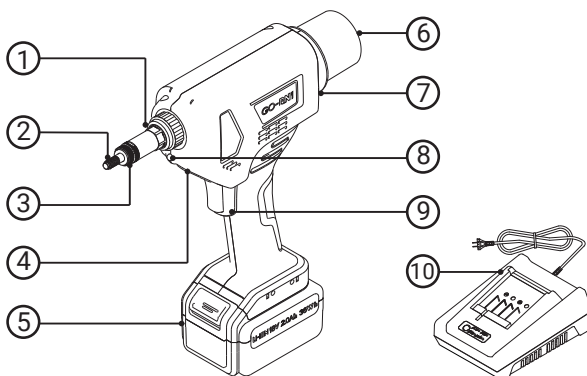

Component

- | | |
|--------------------|----------------|
| ① Threaded sleeve | ⑥ Back cover |
| ② Mandrel | ⑦ Tool housing |
| ③ Steel sleeve | ⑧ LED lighting |
| ④ Function display | ⑨ Trigger |
| ⑤ Battery | ⑩ Charger |

1.1 Capacity / Technical parameters

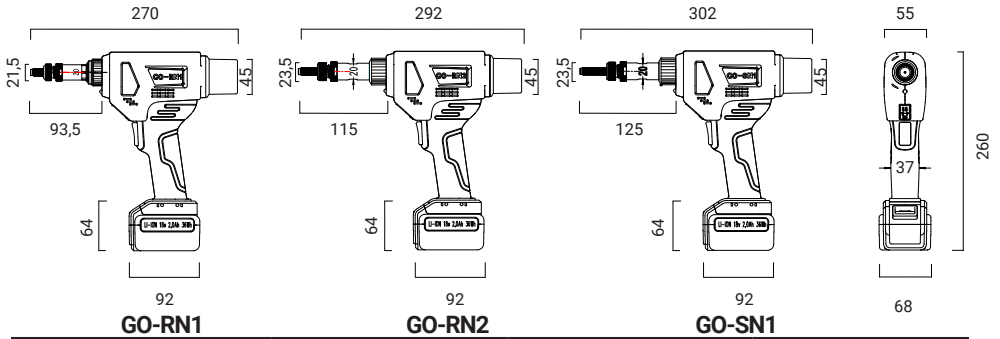

Model	GO-RN1	GO-RN2	GO-SN1
Motor	18V Brushless motor		
Noise level	< 78dB		
Riveting mode	Conventional riveting mode / Fully automatic riveting mode		
Traction force	18000N	27000N	21000N
Stroke	6 mm (adjustable)	9 mm (adjustable)	15,6 mm (adjustable)
Net weight (incl. battery)	1,5Kg	1,64Kg	1,64Kg
Capacity	M3 - M8	M5 - M12	M5 - M10
Material specification	All materials and specifications of round shank, semi and full hexagonal blind rivet nuts.		Split blind rivet nuts - all materials

1.2 Configuration / Accessories

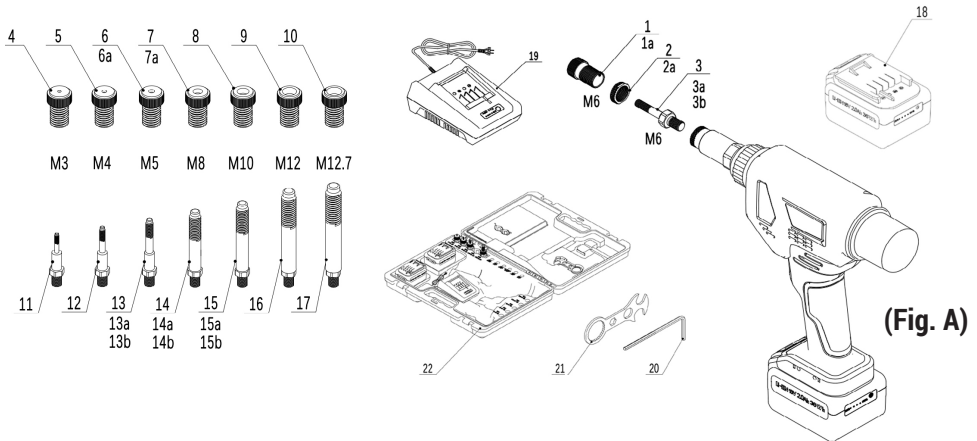

(Fig. A)

1.2 Configuration* / accessories (see fig. A)

NO	Parts description	Code	Spec	Qty.	NO	Parts description	Code	Spec	Qty.
18	Battery Li-Ion 18V 2.0 Ah			2	21	Wrench			1
19	Battery Charger			1	22	ABS casing			2
20	Allen key			1					

GO - RN1 Configuration

NO	Parts description	Code	Spec	Qty.	NO	Parts description	Code	Spec	Qty.
1	Nosepiece		M6	1	7	Nosepiece		M8	1
2	Counter nut			1	11	Mandrel		M3	1
3	Mandrel		M6	1	12			M4	1
4	Nosepiece		M3	1	13			M5	1
5			M4	1	14			M8	1
6			M5						

GO - RN2 Configuration

NO	Parts description	Code	Spec	Qty.	NO	Parts description	Code	Spec	Qty.
1a	Nosepiece		M6	1	13a	Mandrel		M5	1
2a	Counter nut			1	14a			M8	1
3a	Mandrel		M6	1	15a			M10	1
6a	Nosepiece		M5	1	16			M12	1
7a			M8	1					
8			M10	1					
9			M12	1					

GO - SN1 Configuration

NO	Parts description	Code	Spec	Qty.	NO	Parts description	Code	Spec	Qty.
1a	Nosepiece		M6	1	8	Nosepiece		M10	1
2a	Counter nut			1	13b	Mandrel		M5	1
3b	Mandrel		M6	1	14b			M8	1
6a	Nosepiece		M5	1	15b			M10	1
7a			M8	1					

* General configuration

1.3 Part list (Fig. B)

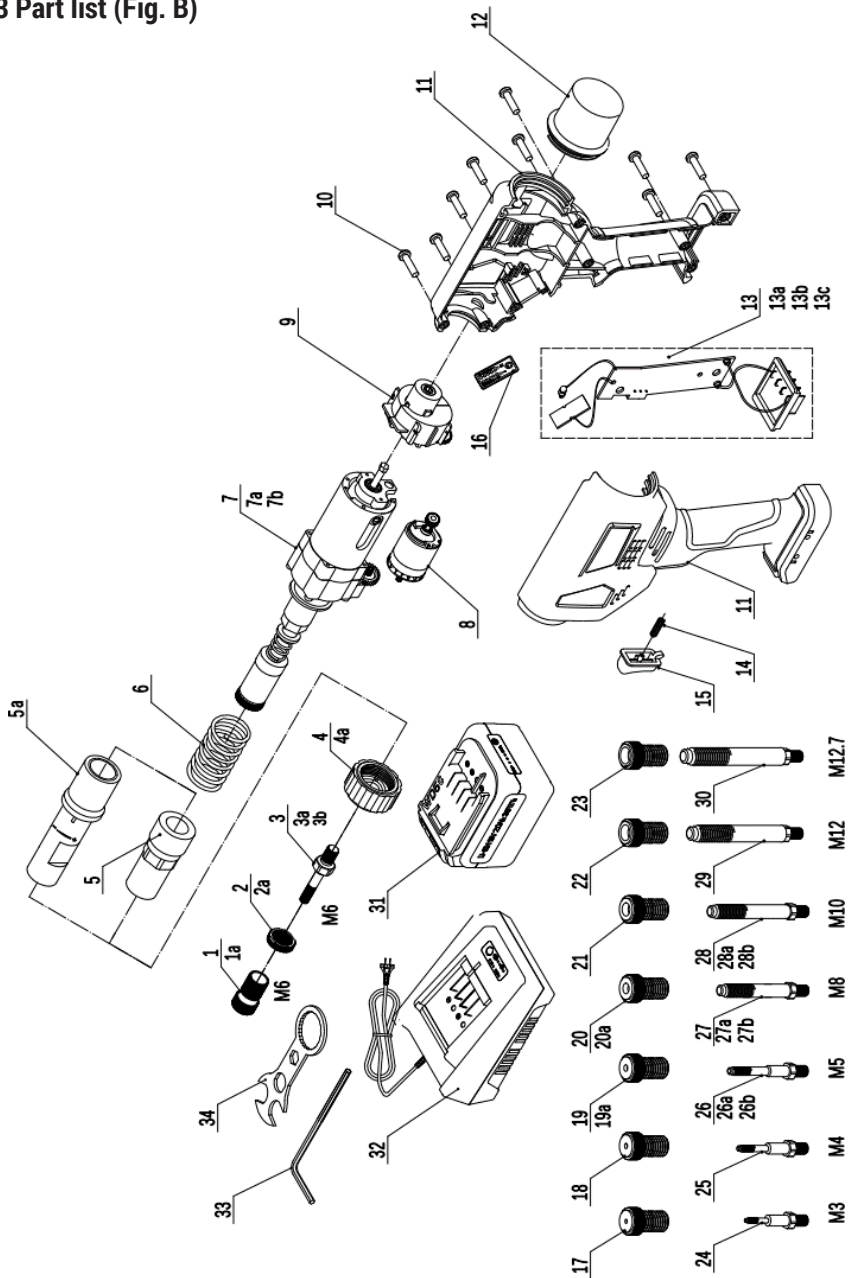

1.4 Tool Parts list of the GO-RN series (see Fig. B)

*Please note that the shaded parts in the list are wear parts, serial numbers 8, 9, 13 are structural parts, serial numbers a, b and c are their own exclusive parts for tools, and the rest are general parts.

List of common parts: GO-RN1, GO-RN2, GO-SN1

NO	Standard Code	Parts description	Qty.	NO	Standard Code	Parts description	Qty.
6		Spring	1	15		Trigger	1
9		Gearbox	1	16		Control unit	1
10		Tool body screw	9	31		Battery Li-Ion 18V 2.0 Ah	1
11		Tool Body GO-RN	1	32		Battery Charger Set	1
12		Back Cover	1	33		Allen key	1
14		Trigger spring	1	34		Wrench	1

GO-RN1 Parts List

NO	Standard Code	Parts description	Qty.	NO	Standard Code	Parts description	Qty.
1		Nosepiece M6	1	17		Nosepiece M3	1
2		Counter nut	1	18		Nosepiece M4	1
3		Mandrel M6	1	19		Nosepiece M5	1
4		Schraubkappe	1	20		Nosepiece M8	1
5		Anvil pedestal assembly	1	24		Mandrel M3	1
7		Gearbox	1	25		Mandrel M4	1
8		Brushless motor	1	26		Mandrel M5	1
13c		PCB Set	1	27		Mandrel M8	1

GO-RN2 Parts List

NO	Standard Code	Parts description	Qty.	NO	Standard Code	Parts description	Qty.
1a		Nosepiece M6	1	20a		Nosepiece M8	1
2a		Counter Nut	1	21		Nosepiece M10	1
3a		Mandrel M6	1	22		Nosepiece M12	1
4a		Screw cap	1	26a		Mandrel M5	1
5a		Anvil pedestal assembly	1	27a		Mandrel M8	1
7b		Gearbox	1	28a		Mandrel M10	1
8b		Brushless motor	1	29		Mandrel M12	1
13b		PCB Set	1				
19a		Nosepiece M5	1				

GO-RN2 Parts List

NO	Standard Code	Parts description	Qty.	NO	Standard Code	Parts description	Qty.
1a		Nosepiece M6	1	13b		PCB-Set	1
2a		Counter Nut	1	19a		Nosepiece M5	1
3b		Mandrel M6	1	20a		Nosepiece M8	1
4a		Screw Cap	1	21		Nosepiece M10	1
5a		Anvil pedestal assembly	1	26b		Mandrel M5	1
7a		Gearbox	1	27b		Mandrel M8	1
8a		Brushless Motor	1	28b		Mandrel M10	1

2. Preparation of the tool

Before operating the riveting tool, please read the following important instructions carefully.

⚠ Danger - 2.1 Exchange of the mandrels

Make sure that you remove the battery from the riveting tool before replacing the mandrel and nosepiece, otherwise there is a risk of injury! Select the appropriate mandrel with corresponding nosepiece that match the size of the blind rivet nut. The procedure for replacing the components is shown in the following illustration:

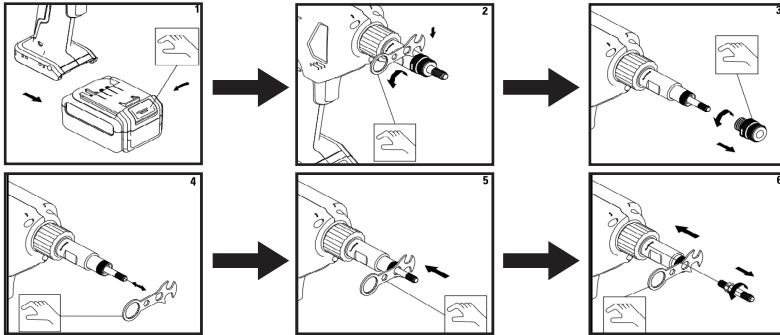

Make sure that the battery has been removed from the tool as shown in figure ① In the order shown above: ② loosen the lock nut with the wrench, ③ unscrew the threaded sleeve and guide the round hole of the spanner onto the threaded mandrel, ④ use the spanner to push down the sleeves in the direction of the arrow ⑤ then unscrew the threaded mandrel.

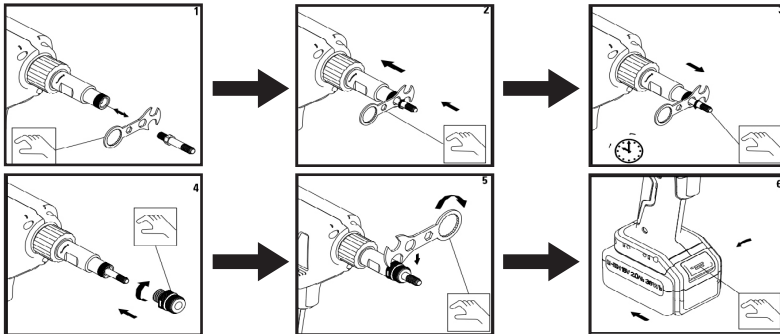

In the sequence shown above, ① the round hole of the wrench is aligned with the mandrel, ② the sleeve is pressed down with the wrench in the direction of the arrow, held, the mandrel is screwed in ③ the mandrel is screwed in in a clockwise direction until the hexagonal part of the mandrel is no longer visible in the sleeve (engaged is after a 60 degree turn, the mandrel is correctly installed ④ The nosepiece is screwed on ⑤ and the counter nut is tightened with the wrench ⑥ The battery is inserted into the tool last.

2.2 Adjustment of the mandrel

Adjust the length of the mandrel correctly according to the length of the blind rivet nut (see fig.) The order of adjustment is as follows:

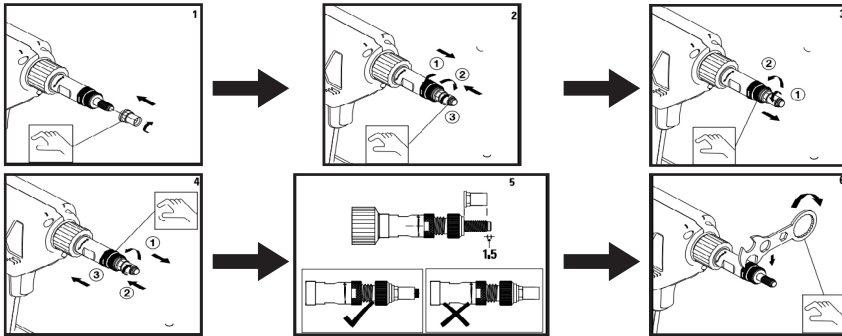

According to the above illustration: ① Screw the blind rivet nut onto the mandrel ② loosen the counter nut, adjust according to ③ and ④ as the figure ⑤ shows, check that the mandrel protrudes ≈ 1.5 mm above the blind rivet nut after adjustment - the mandrel is correctly adjusted ⑥ tighten the counter nut with the wrench in the direction of the arrow.

2.3 Checking the battery

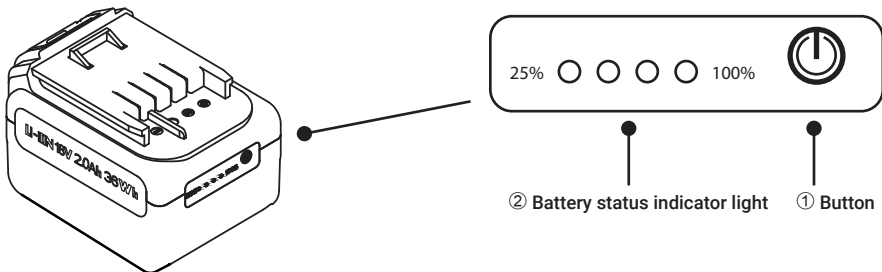

Press button ① once to check the battery.

The battery status indicator light ② is always green:

- Full indicator, 100% energy
- Three lights, 75% energy
- Two lights, 50% energy
- One light, 25% energy. **Please charge!**

2.4 Checking the tool

Install the battery ③ in the direction of the arrow. Press the trigger ②, the white LED illumination lights up ① is always on, indicating that the power is working normally.

- ① LED lighting
- ② Trigger
- ③ Battery

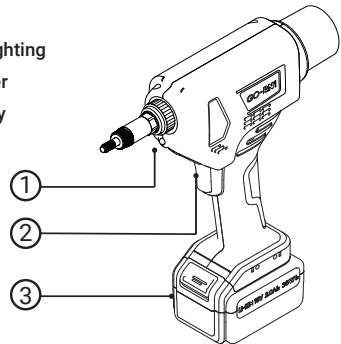

Important note:

You save energy with the automatic sleep mode, no operation within one minute, the white illumination light LED goes out automatically, the tool goes into automatic sleep mode, press the trigger again to restore power.

3. Function setting

Read the following particularly important notes carefully when you are ready to start using the function settings.

3.1 Adjusting the traction force

The function is preset at the factory:

Stroke: 0.3 - 0.8 mm (indicator light 1)

Traction mode: (L) "green light on, not flashing".



The tractive force mode (L) stands for general tractive force.

Tractive force mode (H) stands for increased tractive force.

Please set the traction force according to the specifications and the strength of the blind rivet nut. Before setting the traction force, enquire about the technical values of the blind rivet nut and its range of application.

⚠ To avoid excessive stress/damage to the mandrel, it is strongly recommended to set the pull force mode to L when riveting small blind rivet nuts.

Press the button ③ for 1.5 seconds to set the pull force mode. Each time you press it, the tension indicator ② always lights up green and the tension is alternately switched between L-H.

- ① Stroke indicator light 
- ② Traction force indicator light 
- ③ Button 

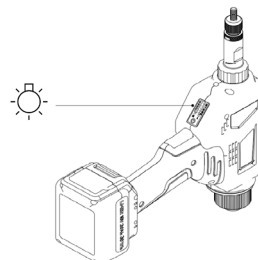
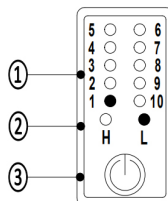

3.2 Setting the stroke

The stroke setting (indicator lights) can be set/adjusted between 1-10. Before adjusting the stroke, please read the following instructions to distinguish between the different types of units (GO-RN1, GO-RN2 and GO-SN1).

Stroke adjustment on the GO-RN1 (adopt the principle for the GO-RN2 and GO-SN1)

First press the trigger button of the tool, then press the button ③ to start the stroke setting. The stroke indicator light ① lights up and the green light flashes slowly in riveting mode L (factory setting). To increase the stroke by 0.2 mm, press the button ③ again, the stroke indicator light ① flashes with a fast flashing green light. The stroke has been increased by 0.4 mm, press button ③ again and the stroke is increased by a further 0.2 mm to 0.6 mm, the green light is permanently on. The stroke setting is between 1-6 mm, 0.2 mm per increased gear (see diagram 2), the total stroke of 6 mm according to diagram (3) is the maximum stroke setting (all 10 lights are on). Press the button again briefly, after the full display (all lights), and the stroke goes back to 0.2 mm (see figure under 1). If there is no confirmation by pressing the trigger within 1 minute, the white light goes out automatically and the power supply is restored by pressing the trigger. The lifting and pulling force display on the function display is saved as the last setting and is displayed when the unit is started up again.

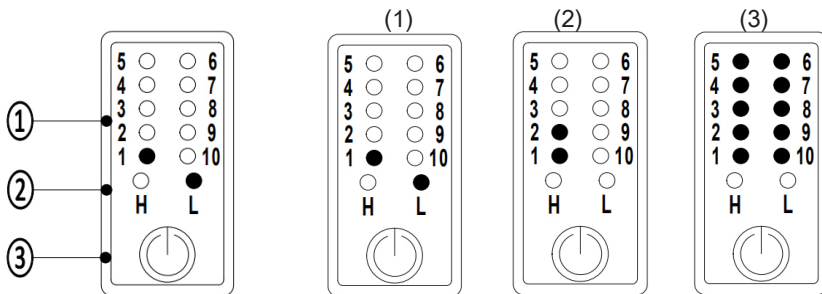

Stroke/gear adjustment and display	GO-RN1	GO-RN2	GO-SN1
1 gear higher, the green light flashes slowly	0,2 mm	0,3 mm	4,0 mm
2 gears higher, the green light flashes quickly	0,4 mm	0,6 mm	4,4 mm
3 gears higher, the green light is on and not flashing	0,6 mm	0,9 mm	4,8 mm
Full stroke (all gears), the green light is always on	6 mm	9 mm	15,6 mm

Model	GO-RN1			Model	GO-RN2			Model	GO-SN1		
	The green light flashes slowly	The green light flashes quickly	The green light is on and not flashing		Stroke / Gear	The green light flashes slowly	The green light flashes quickly		The green light is on and not flashing	Stroke / Gear	The green light flashes slowly
№1	0,2	0,4	0,6	№1	0,3	0,6	0,9	№1	4,00	4,40	4,80
№2	0,8	1,0	1,2	№2	1,2	1,5	1,8	№2	5,20	5,60	6,00
№3	1,4	1,6	1,8	№3	2,1	2,4	2,7	№3	6,40	6,80	7,20
№4	2,0	2,2	2,4	№4	3,0	3,3	3,6	№4	7,60	8,00	8,40
№5	2,6	2,8	3,0	№5	3,9	4,2	4,5	№5	8,80	9,20	9,60
№6	3,2	3,4	3,6	№6	4,8	5,1	5,4	№6	10,00	10,40	10,80
№7	3,8	4,0	4,2	№7	5,7	6,0	6,3	№7	11,20	11,60	12,00
№8	4,4	4,6	4,8	№8	6,6	6,9	7,2	№8	12,40	12,80	13,20
№9	5,0	5,2	5,4	№9	7,5	7,8	8,1	№9	13,60	14,00	14,40
№10	5,6	5,8	6,0	№10	8,4	8,7	9,0	№10	14,80	15,20	15,60

3.3 Setting the riveting mode (Important note before setting the riveting mode)

Before switching the riveting mode, please refer to the specifications and material properties of the blind rivet nut, as well as other information about the capacity, riveting condition, to select the appropriate riveting mode. There are two riveting modes: the fully automatic riveting mode and the conventional riveting mode.

3.4 Riveting in fully automatic riveting mode (with flashing green light)

The fully automatic riveting mode is possible by the "flashing green light" ② in riveting mode (L) and (H). It is recommended to use the fully automatic riveting mode only with partial and full hexagonal shank blind rivet nuts. The blind rivet nut has previously been inserted into the workpiece (hole) and the mandrel is automatically screwed into the blind rivet nut (threading), then automatically pulls the blind rivet nut (deformation) (without actuating the trigger), and also spindles off automatically. The fully automatic riveting mode is suitable for assembly line work and significantly increases capacity.

3.5 Riveting in conventional riveting mode (with green light)

The conventional riveting mode is possible by the "always green light" ② in riveting mode (L) and (H). It is recommended to use the conventional riveting mode with round shank blind rivet nuts. In the conventional riveting mode, the blind rivet nut is automatically threaded onto the mandrel, lead is applied to the mandrel, the blind rivet nut is inserted into the hole on the workpiece, the trigger is actuated and the blind rivet nut deforms. Finally, the blind rivet nut automatically spindles off the mandrel.



Special note, the fully automatic riveting mode is only suitable for assembly line operation, in combination with semi or full hexagonal blind rivet nuts. For round shank blind rivet nuts we recommend the conventional riveting mode.

Function display panel

To switch to fully automatic riveting mode, press the key ③ button for 3 seconds and the green light flashes!

To switch to conventional riveting mode, the key ③ must be pressed for pressed for 3 seconds and the green light no longer flashes, it is only green.

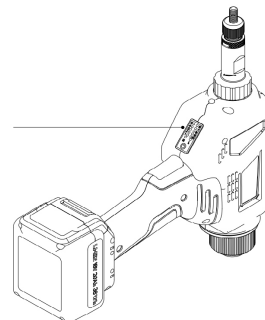
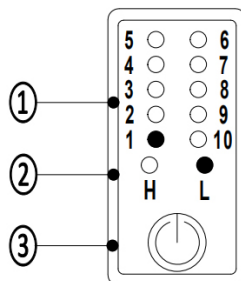

4. Tool Operation (Important tips before starting work)

Please charge the battery to 100% before first use (according to the relevant government regulations). Please ensure that charging does not stop below 50% of the battery's capacity.

4.1 Instructions for presetting the blind rivet nut

The functions to be set in advance should be followed according to the specification of the blind rivet nut, the thickness and the thickness of the workpiece. Due to different types and specifications of blind rivet nuts that may be provided by different suppliers, the installation performance will vary greatly. Therefore, pre-installation (sample riveting) is required when the function is set (before official riveting) (Fig. 1) We recommend that you use GOEBEL brand blind rivet nuts for optimum processing.

(1) Screw the blind rivet nut manually by $\frac{1}{2}$ turn according to the above illustration, vertically and straight onto the mandrel! (2) Press the blind rivet nut in the direction of the arrow and the blind rivet nut is automatically spindled on. (3) Press the trigger button and the blind rivet nut is pulled (4) The test riveting process is completed, the mandrel automatically spindles the blind rivet nut. Check the riveting condition according to the above illustration and check whether the riveting condition is satisfactory.

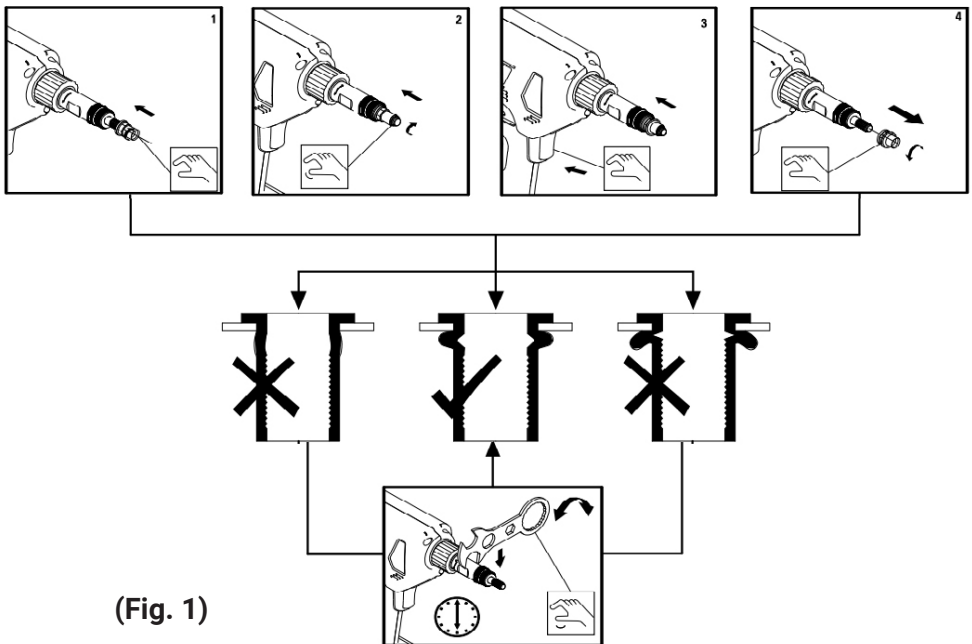

(Fig. 1)

4.2 Checking the set blind rivet nut

If after the setting process the result of the blind rivet nut setting appearance does not correspond to the picture in the middle, it shows that the stroke has not been set to the most suitable setting. Further fine adjustment can be made by adjusting (+/-) with the tool wrench (see illustration). If the fine adjustment does not lead to the desired goal, please check/perform instruction 3.2 Adjusting the stroke again.

4.3 Unscrewing blind rivet nuts manually

Important note: Too high a traction force or a too long working stroke (incorrect setting) can damage the blind rivet nut thread. In addition, the wrong setting can cause the thread of the blind rivet nut to become severely deformed and the automatic unwinding of the blind rivet nut is blocked. The blind rivet nut has caught and is still seated on the mandrel. Use the Allen key to unscrew the blocked blind rivet nut manually.

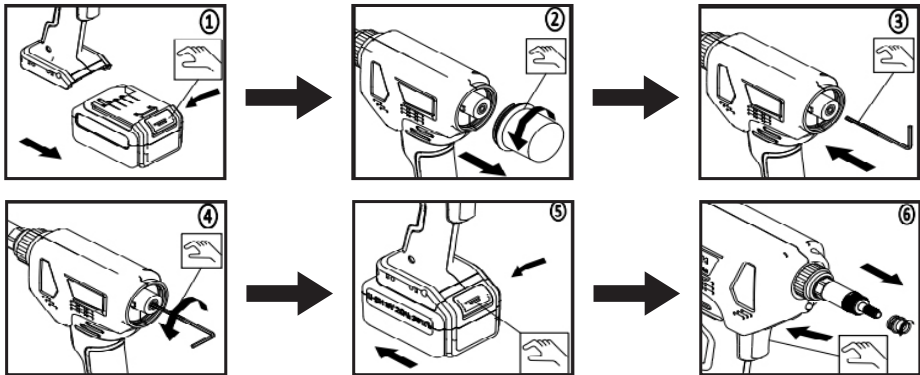

Remove the battery according to figure ①, unscrew the protective cap in the direction of the arrow to remove the protective cap, insert the Allen key into the hexagonal hole at the rear end in the direction of the arrow in figure ③, loosen the blind rivet nut blocked by the threaded mandrel counterclockwise in the direction of the arrow in figure ④, install the battery in figure ⑤, see figure ⑥, the threaded mandrel extends automatically after pressing the release button.

4.4 Setting instructions for the riveting process

Set the blind rivet nut in a vertical position.

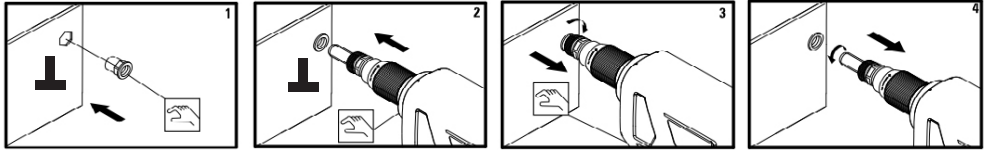

The blind rivet nut is screwed onto the mandrel in the direction of the arrow ①, make sure that this is done vertically! ② Insert the blind rivet nut into the workpiece in the direction of the arrow, again vertically! ③ Press the trigger to rivet the blind rivet nut. ④ After the setting process, the mandrel retracts automatically (unwinding of the blind rivet nut) and the riveting process is completed.

4.5 Riveting in special applications

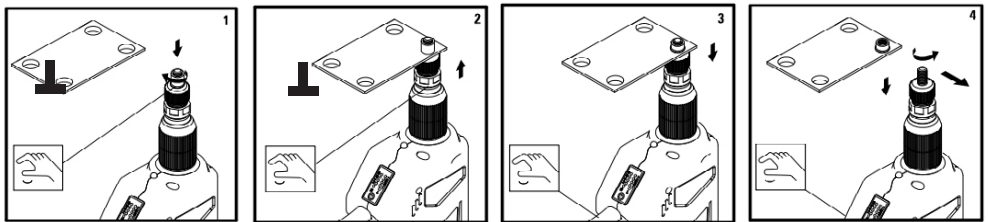

The blind rivet nut is placed on the mandrel in the direction of the arrow and automatically spindled on ①, please note the vertical alignment! ② The blind rivet nut is inserted into the workpiece in the direction of the arrow, please note the vertical alignment! ③ Press the trigger to rivet the blind rivet nut. ④ After the setting process, the mandrel retracts automatically (unwinding of the blind rivet nut) and the riveting process is completed.

5. Charger & Battery

5.1 Technical parameters

Charger

Output: 18V - 2.0Ah

Input: 100 - 240V / 50 - 60HZ / 1 A

Net weight: 0,27Kg

Battery

Output: 18V - 2.0Ah - 36Wh

Net weight: 0,37Kg

5.2 Charger usage

The charger is connected to the power supply, the green indicator light ① is always on, works properly and charges the battery in the direction of the arrow.

Operation	Charge control light (1)	Symbols (2) Explanation	Measures
Battery charged in charger	▶ Red light on	▶ The battery is in good condition. The charging time is about one hour.	▶ In good condition
	▶ Green light on	▶ Battery malfunction. Cannot be charged.	▶ Immediately disconnect the power supply, remove the battery and replace it with a new battery.
The battery is charged	▶ Green light on	▶ The battery is full. Please remove the battery.	▶ In good condition
	▶ Red light on	▶ When the internal temperature rises, the charger stops working.	▶ Immediately disconnect the power supply, remove the battery and replace it with a new battery.

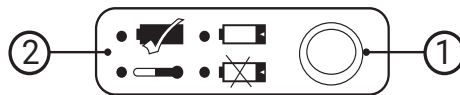
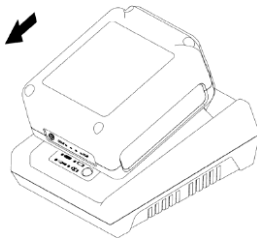

① Charge indicator light

② Loading symbols

5.3 Battery usage

- During use, please check (see P9 Battery check) the battery power.
- The battery has deep discharge protection (ECP) and can be recharged about 1000 times.
- Do not use the charger until the battery has cooled down sufficiently.
- If the battery's operating time is significantly reduced during normal use, this indicates that the battery should be replaced.

		Questions	Answers
Battery	▶	Is it okay not to use them for a long time	▶ Charge the battery every 6 months, otherwise it may deteriorate in performance after 6 months.
	▶	Does charging after each use affect battery life	▶ Suggestion: When the remaining battery time is only 25% (a light on the display) or when the battery is exhausted, it should be recharged to increase the battery life.
Usage	▶	If the tool housing is used continuously in conventional riveting mode (D) for a certain period of time, will the heating in the tool housing affect normal use?	▶ As the high-speed motor causes the gear to rotate, the heat generated during the riveting process is transferred to the outside, which does not affect the normal use of the tool. The user is advised to wear suitable protective gloves.

7. Troubleshooting

		Malfunction	Probable cause	Correction of defects
While charging	▶	The battery is plugged into the charger and the green light is on	▶ Battery malfunction or damage, error, charging not possible.	▶ Stop charging immediately, remove the battery and replace it with a new battery.
	▶	Red light is on while the battery is charging	▶ Abnormal charging temperature (battery overheating) outside normal range (0°C~45°C)	▶ Immediately switch off the power, remove the battery and check the charger
U S A G E	▶	All displays on the function panel flash	▶ Low power alarm	▶ Remove the battery
	▶	The indicator light flashes once within a certain period of time and switches off after 15 seconds.	▶ Motor short-circuit alarm	▶ Please send the battery to qualified, professional maintenance personnel for inspection and repair. If in doubt, please contact the authorised dealer in good time for advice and repair.
	▶	The indicator light flashes within a certain period of time and switches off after 15 seconds.	▶ Overheating alarm of the control unit	
	▶	The indicator light flashes 4 times within a certain period of time and switches off after 15 seconds.	▶ Engine blockage alarm	
	▶	The indicator light flashes 5 times within a certain period of time and switches off after 15 seconds.	▶ Switch-on error or abnormally high current flow	
	▶	The blind rivet nut was not set correctly.	▶ Thread of blind rivet nut damaged.	▶ Use a new blind rivet nut.
	▶		Mandrel damaged.	▶ Replace the mandrel (see P8 Replacing accessories).
	▶		The setting head of the blind rivet nut is not in contact with the threaded sleeve.	▶ Length of mandrel is incorrectly adjusted; adjust according to the length of the blind rivet nut (see S9).
	▶		Discharge the battery. Check the power indicator panel.	▶ Charge (see S9: Battery check, for use with P14 batteries and chargers).
	▶	The mandrel cannot be pulled in	▶ Too high traction force or too long working stroke, as a result of which the thread of the blind rivet nut will be deformed / deformed or damaged.	▶ Unscrew the blind rivet nut manually with the Allen key (see 4.3) Unscrewing blind rivet nuts manually. Adjust the traction force or working stroke (see 3.1) Adjusting the traction force and 3.2) Adjusting the stroke
	▶		Blind rivet nut thread damaged	▶ Use a new blind rivet nut.
	▶		Blind rivet nut thread not centred or perpendicular on flange/set head	▶ Use a suitable blind rivet nut.
	▶		The intended hole of the riveted plate is not perpendicular to the plane, or the accuracy of the rounding does not meet the requirements.	▶ Check the intended bore of the workpiece and machine it after
▶	Premature termination of the riveting process before the tool stops working completely.		▶ Wait until the tool stops working completely. 4.) Tool Operation (Important tips before starting work)	
▶	The blind rivet nut is not perpendicular to the intended hole of the workpiece during processing.	▶	▶ Make the correct setting for operation. 4.) Tool Operation (Important tips before starting work)	
▶		Loose blind rivet nut after rivet installation	▶ The traction force is too low.	▶ Adjust the traction force correctly (see 3.1 Adjusting the traction force)
			▶ The blind rivet nut is loosened before the set working stroke is reached.	▶ Set the working stroke correctly (see 3.2) Setting the stroke

If the above method does not remedy the situation, the riveting tool must be repaired by professional personnel or the tools must be returned to the seller or manufacturer for repair!

8. Protection conditions & CE certification

Warranty period & maintenance protection

Our products offer lifetime after-sales service and if any manufacturing quality problem is found in use, we provide three warranties.

The warranty period for this tool is 1 year and the start date is based on the sales invoice.

Damage caused by normal wear and tear, overloading, improper use or by human hand is not covered by the warranty.

For the quality problem of the tool itself, free repair or replacement within the warranty period.

Free repair or replacement under warranty, only complete tools that have not been opened independently will be accepted. Wear parts are not covered by the warranty. In case of abnormal use, the manufacturers are not responsible for the quality and do not take into account storage, accident, misuse and loss and failure due to non-conformity of the equipment. The highest liability for damages is limited to the value of the product itself and does not cover the relevant parts.

If you have any questions, please contact your local dealer or GOEBEL directly for assistance immediately.

We hereby declare that this battery tool complies with the following standards and the standard documentation when used in accordance with the operating instructions.

CE Certification

EC Compliance Statement
EN 62841-1:2015/AC:2015,
EN 60335-1:2012/A11:2014,

EN 55014-1:2006+A1:2009+A2:2011,
EN 55014-2:2015, EN 61000-3-2:2014,
EN 61000-3-3:2013

related to CE Directive(s):
2006/42/EC (Machinery)

2014/35/EU (Low Voltage)

2014/30/EU (Electromagnetic Compatibility)



Marcel Goebel
Geschäftsführer

