

DIN 7504 K Hexagon Washer Head self drilling screw 6.3x25mm, with assembled epdm light grey washer diameter: 16mm, Drilling Capacity max. 6.0mm steel, drilling point No. 3 TYPE AB, ZINC PLATED 4-6 micro CODE: 4010563250.

DRILLING
SCREW

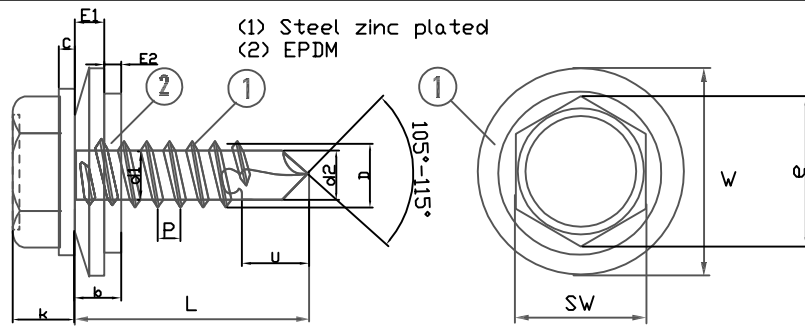

diámetro	6.3	ISO		6.3	ISO		
PITCH (P)	1.8	1478	MAJOR DIA. (D)	6.03-6.25	1478		
HEAD DIA. A/F	9.88-10.00	7504	MINOR DIA. (d1)	4.70-4.88	1478		
HEAD HEIGHT (k)	6.15-6.45	7504	DRILL POINT DIA. (d2)	4.8-5.4	10666		
(C)	1.0	7504	FLUTE LENGTH (U)	8.5-9.5			
E1 steel washer E2 EPDM	1.75 1.70		EPDM (W)	16			
Zinc plated white/blue	4-6micro	4042	e	min. 10.95	7504		
steel no. material	C1022						

TOLERANCE ON LENGTH	25mm±1mm Tolerances according to ISO 4759-1, all dimensions in mm, Acceptance inspection according to ISO 3269:2000,						
---------------------	--	--	--	--	--	--	--

DRILLING STANDARD	PLATE THICKNESS	3.0+3.0=6mm	ROTATIONAL SPEED	1800RPM	MAX SEC.	13.0 SEC	ISO
	AXIAL FORCE	350 (N)	LOADING	35.8 KGS			10666

MECHANICAL PROPERTY	SIZE	6.3	CORE HARDNESS	MAX 425 HV	BREAKING TORQUE	Min 169 (kg-cm)	10666
	MATERIAL	C1022	SURFACE HARDNESS	MIN 560 HV	CARBON PENETRATE REQUIREMENT	0.10-0.28	10666

customer Nr.:	production Nr.:	tolerances according to ISO 4759-1, all dimensions in mm, Acceptance inspection according to ISO 3269				
designed G. Kramme	checked M. Goebel	Name of file 4010563250	date 2007/10/19	scale		
GOEBEL GMBH		CODE 4010563250 DIN 7504				
		Drawing No. 3	REV0	paper 1/1		